

# Electromechanical Cylinder EMC

The Drive & Control Company

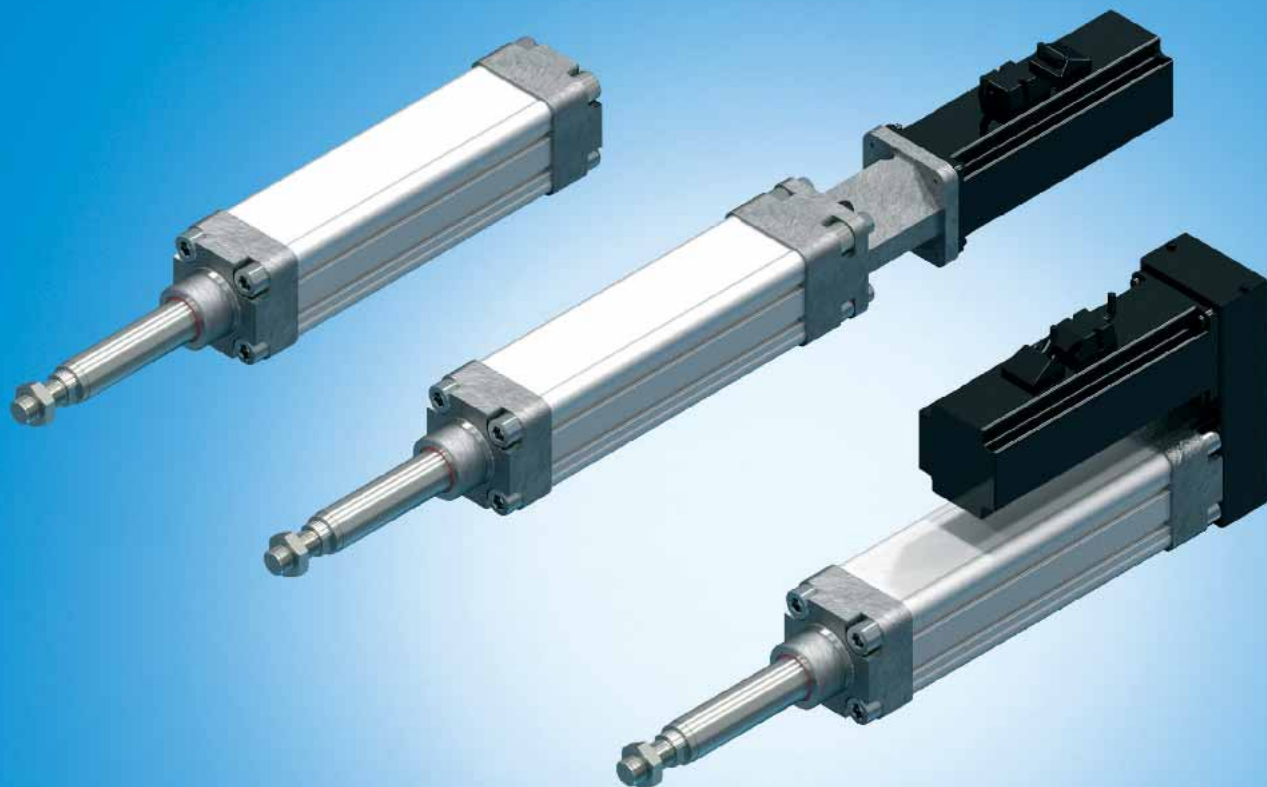

# Linear Motion and Assembly Technologies

Ball Rail Systems  
Roller Rail Systems  
Linear Bushings and Shafts

Ball Screw Drives  
Linear Motion Systems

Basic Mechanical Elements  
Manual Production Systems  
Transfer Systems



# Electromechanical Cylinder EMC

<b>Product Overview</b>	<b>4</b>
<b>Technical Data and Dimensions EMC</b>	<b>6</b>
<b>Dimensions EMC with Motor Mount and Motor</b>	<b>8</b>
<b>Dimensions EMC with belt side drive</b>	<b>10</b>
<b>Motors</b>	<b>12</b>
AC servo motors MSK	14
Servo motors MSM	15
3-phase stepper motors VRDM	16
<b>Accessories</b>	<b>18</b>
<b>Permissible Speeds</b>	<b>20</b>
<b>Permissible Drive Torque</b>	<b>22</b>
<b>Permissible Axial Force</b>	<b>24</b>
<b>Configuration and Ordering</b>	<b>26</b>
<b>Inquiry / Order Form</b>	<b>30</b>

## Product Overview

### Electromechanical Cylinder EMC

Because of the actuator choices that electromechanical drive solutions offer, they are becoming more and more popular as an alternative to fluid driven technology. Rexroth has released an Electromechanical Cylinder EMC that can in many cases efficiently replace pneumatic and hydraulic cylinders and result in conceptual advantages. Combinations of the various technologies can also result in new application possibilities.

The mechanics are based on established rolled precision ball screw drives available in all current diameter and lead combinations. Performance characteristics such as positioning accuracy, thrust or speed can be optimized to meet the requirements of each specific application.

Through the use of generously sized angular-contact thrust ball bearings LAN, the load rating of the ball screw drive is used to its maximum potential. There are also many choices and possibilities when it comes to drive configurations and connecting parts.

#### System Advantages

- Many sizes to choose from
- Integrated ball screw drive ensures exact positioning and powerful thrust capability
- Various motor mounts for direct or belt drives
- Compact construction - dynamic drive
- Extensive series of attachments to match for every application area
- Quick assembly
- Compatible with other products from Bosch Rexroth

#### Ball screw drives used

EMC size	d <sub>0</sub>	Ball screw						
		Lead P						
		5	10	16	20	25	32	40
32	12							
40	16							
50	20							
63	25							
80	32							
100	40							

#### Application examples

There are many application areas where an EMC can be used, either as a replacement for, or in conjunction with pneumatic and hydraulic technology.

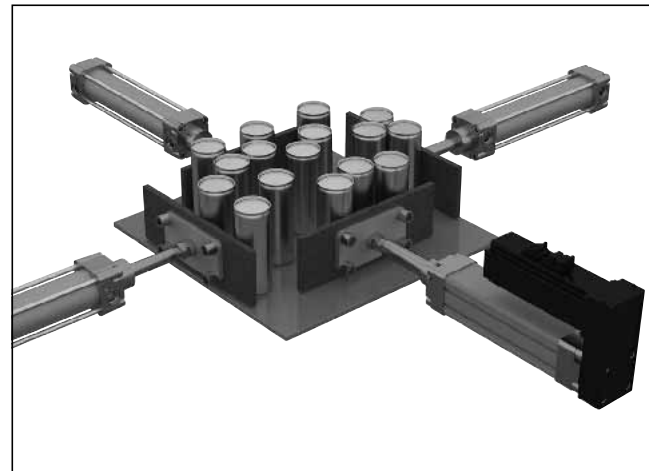

#### Packaging technology

Pallet table with three pneumatic and one EMC cylinder as a precise guide.

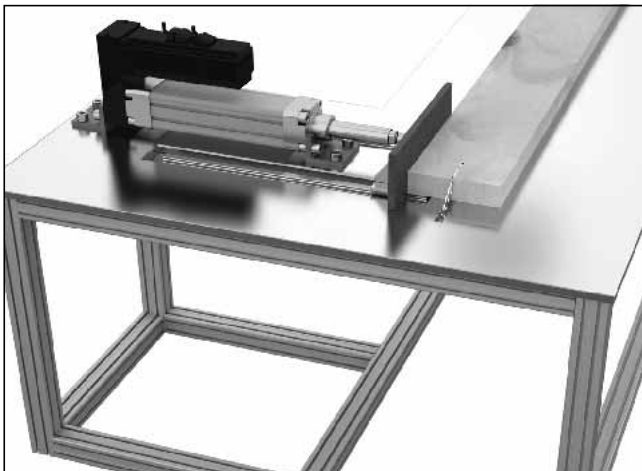
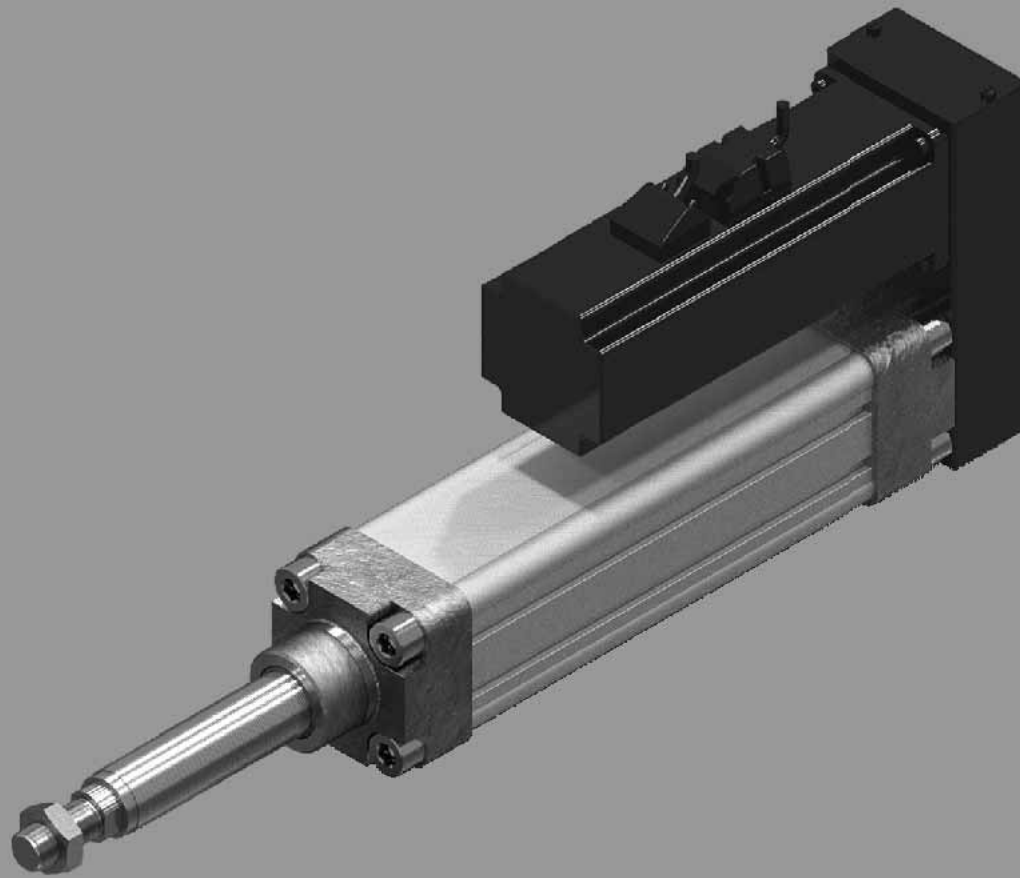

Machine tools or woodworking machines  
Adjustable mechanical stop for a saw

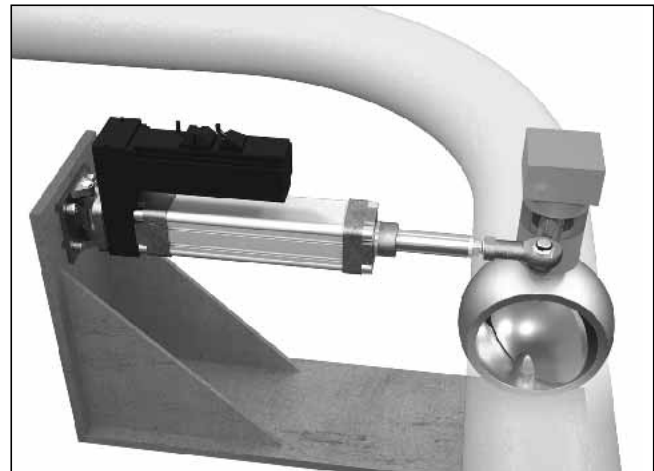

Dispensing systems  
Valve timing

## Technical Data and Dimensions EMC

Sizes 32 to 100 to follow the standard cylinder series according to ISO 15552

Built-in ball screw drives have a diameter of 12 mm to 40 mm

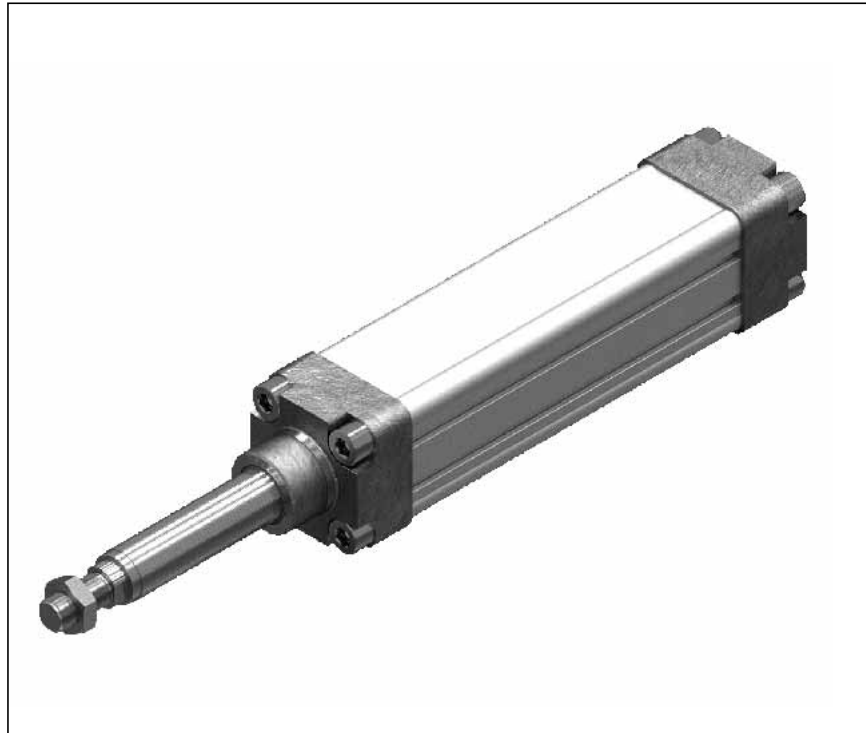

Stroke H per customer specifications (minimum stroke 100 mm)

$$L_K = V_B + H$$

$$L_{EMC} = L_K + W_H + A_M$$

E M C Size	Ball screw		Load capacities $C_{EMC}$ (N)	Max. axial force $F_{max EMC}$ (N)	Permissible drive torque at drive journal $M_{TA max}$ (Nm)	Speed $v_{max}^{1)}$ (m/min)	Stroke $H_{max}$ (mm)
	$d_0$ (mm)	Lead P (mm)					
32	12	5	3800	500	0.50	34.0	750
	12	10	2500	300	0.70	68.0	750
40	16	5	12300	3000	3.20	23.0	750
	16	10	9600	2800	5.00	46.0	750
	16	16	9600	2100	6.00	73.6	750
50	20	5	14300	6000	5.70	19.0	900
	20	20	13300	3400	12.30	76.0	900
63	25	5	15900	10000	14.80	16.5	1200
	25	10	15700	10000	26.10	33.0	1200
	25	25	14700	9400	41.70	82.5	1200
80	32	5	21600	17000	18.60	15.0	1500
	32	10	26000	17000	33.80	30.0	1500
	32	20	19700	14700	52.00	60.0	1500
	32	32	19500	10800	61.60	96.0	1500
100	40	5	29000	21000	54.10	11.0	2000
	40	10	29000	21000	58.40	22.0	2000
	40	20	29000	21000	94.90	44.0	2000
	40	40	29000	17600	124.60	88.0	2000

1)  $v_{max}$  is dependent on the stroke, see speed diagram

All dimensions for stroke  $H = 0$  mm

$K_V$  = Width across flats of the nut

$SW$  = Width across flats of the bolt

Shown in a retracted position

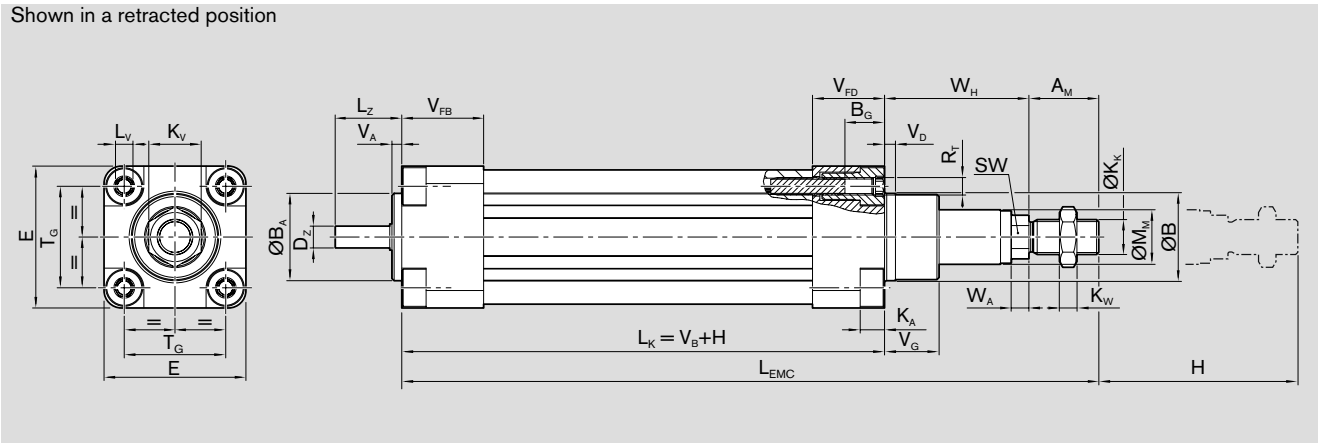

EMC size	Ball screw size	Dimensions (mm)											
		A <sub>M</sub> -0.1	B e11	B <sub>A</sub> e11	B <sub>G</sub>	D <sub>Z</sub> h7	E ± 0.1	K <sub>K</sub>	K <sub>A</sub>	K <sub>V</sub>	L <sub>V</sub> E11	L <sub>Z</sub>	K <sub>W</sub>
32	12x5Rx3-4	22	30	30	16	5	47	M10x1.25	6.65	17	6	17	6
	12x10Rx2-2	22	30	30	16	5	47	M10x1.25	6.65	17	6	17	6
40	16x5Rx3-4	24	35	35	16	8	53	M12x1.25	6.65	19	6	21	7
	16x10Rx3-3	24	35	35	16	8	53	M12x1.25	6.65	19	6	21	7
	16x16Rx3-3	24	35	35	16	8	53	M12x1.25	6.65	19	6	21	7
50	20x5Rx3-4	32	40	40	16	10	65	M16x1.5	11.15	24	8	26	8
	20x20Rx3.5-3	32	40	40	16	10	65	M16x1.5	11.15	24	8	26	8
63	25x5Rx3-4	32	45	45	16	15	75	M16x1.5	11.15	24	8	31	8
	25x10Rx3-4	32	45	45	16	15	75	M16x1.5	11.15	24	8	31	8
	25x25Rx3.5-3	32	45	45	16	15	75	M16x1.5	11.15	24	8	31	8
80	32x5Rx3.5-4	40	55	55	16	18	95	M20x1.5	15.15	30	15 -0.05/-0.2	42	10
	32x10Rx3.969-5	40	55	55	16	18	95	M20x1.5	15.15	30	15 -0.05/-0.2	42	10
	32x20Rx3.969-3	40	55	55	16	18	95	M20x1.5	15.15	30	15 -0.05/-0.2	42	10
	32x32Rx3.969-3	40	55	55	16	18	95	M20x1.5	15.15	30	15 -0.05/-0.2	42	10
100	40x5Rx3.5-5	40	65	65	16	25	115	M20x1.5	15.15	30	15 -0.05/-0.2	53	10
	40x10Rx6-4	40	65	65	16	25	115	M20x1.5	15.15	30	15 -0.05/-0.2	53	10
	40x20Rx6-3	40	65	65	16	25	115	M20x1.5	15.15	30	15 -0.05/-0.2	53	10
	40x40Rx6-3	40	65	65	16	25	115	M20x1.5	15.15	30	15 -0.05/-0.2	53	10

EMC size	Ball screw size	Dimensions (mm)												
		M <sub>M</sub> f8	R <sub>T</sub>	SW	T <sub>G</sub>	V <sub>A</sub> ± 0.1	V <sub>B</sub>	V <sub>FB</sub>	V <sub>FD</sub>	V <sub>G</sub> ± 0.1	V <sub>D</sub>	W <sub>A</sub>	W <sub>H</sub>	
32	12x5Rx3-4	18	M6	10	32.5 ±0.35	4	132	30	30	16	5	6	26	
	12x10Rx2-2	18	M6	10	32.5 ±0.35	4	136	30	30	16	5	6	26	
40	16x5Rx3-4	20	M6	10	38.0 ±0.35	4	134	33	30	20	5	6	30	
	16x10Rx3-3	20	M6	10	38.0 ±0.35	4	143	33	30	20	5	6	30	
	16x16Rx3-3	20	M6	10	38.0 ±0.35	4	159	33	30	20	5	6	30	
50	20x5Rx3-4	25	M8	16	46.5 ±0.45	4	142	38	33	25	5	8	37	
	20x20Rx3.5-3	25	M8	16	46.5 ±0.45	4	180	38	33	25	5	8	37	
63	25x5Rx3-4	30	M8	16	56.5 ±0.55	4	148	40	33	25	5	8	37	
	25x10Rx3-4	30	M8	16	56.5 ±0.55	4	167	40	33	25	5	8	37	
	25x25Rx3.5-3	30	M8	16	56.5 ±0.55	4	199	40	33	25	5	8	37	
80	32x5Rx3.5-4	38	M10	22	72.0 ±0.60	4	158	44	35	33	5	10	46	
	32x10Rx3.969-5	38	M10	22	72.0 ±0.60	4	187	44	35	33	5	10	46	
	32x20Rx3.969-3	38	M10	22	72.0 ±0.60	4	195	44	35	33	5	10	46	
	32x32Rx3.969-3	38	M10	22	72.0 ±0.60	4	230	44	35	33	5	10	46	
100	40x5Rx3.5-5	50	M10	22	89.0 ±0.60	4	166	48	35	38	5	10	51	
	40x10Rx6-4	50	M10	22	89.0 ±0.60	4	185	48	35	38	5	10	51	
	40x20Rx6-3	50	M10	22	89.0 ±0.60	4	203	48	35	38	5	10	51	
	40x40Rx6-3	50	M10	22	89.0 ±0.60	4	258	48	35	38	5	10	51	

## Dimensions EMC with Motor Mount and Motor

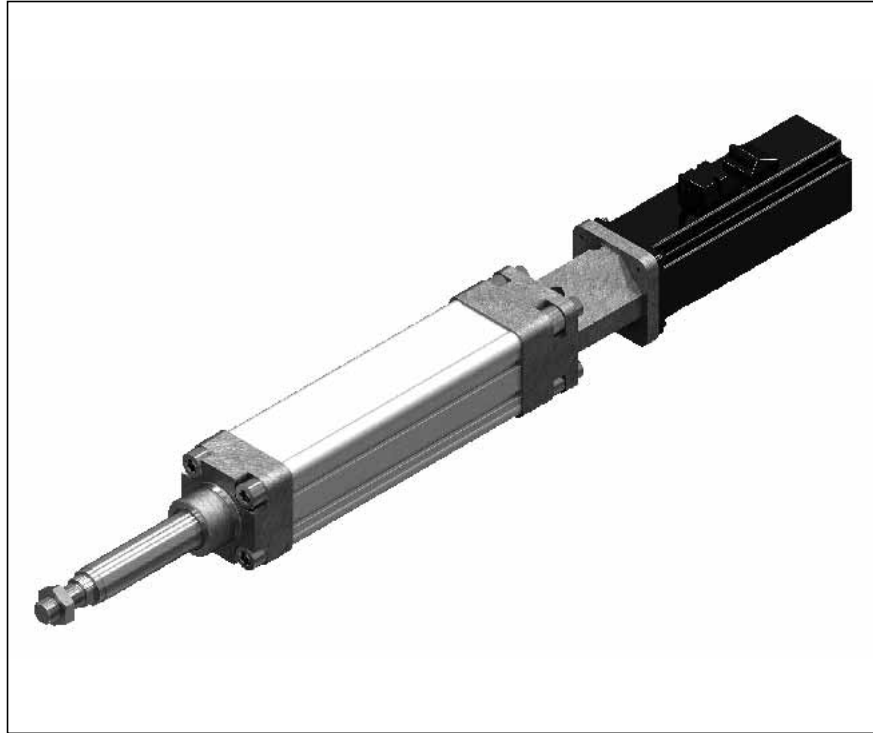

### Attaching the accessories

The accessory parts are screwed into the internal thread of the end cap nut. These screws are included in the delivery of the EMC and are identical regardless of EMC size.

$L_T$  = Depth of the screw in the end cap nut

$R_T$  = Thread diameter

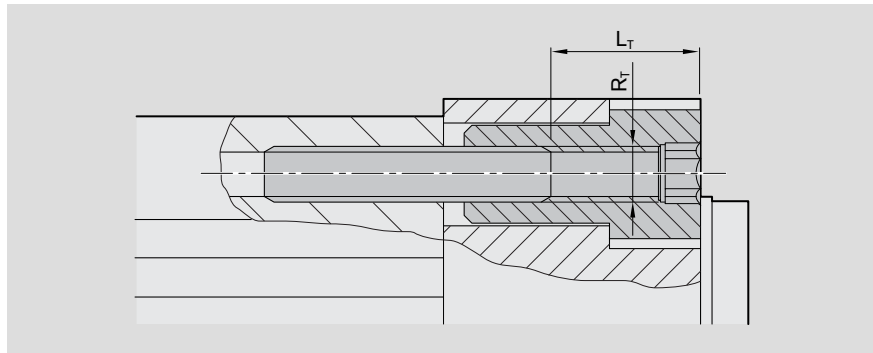

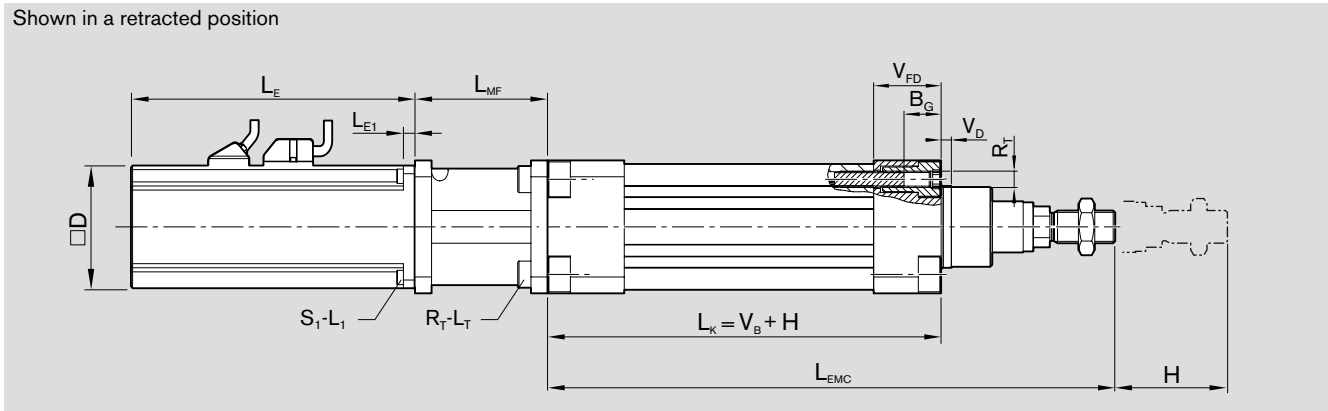

$$L_{MF0} = L_{EMC} + L_{MF} + L_E$$

EMC size	Motor	Dimensions (mm)												
		B <sub>G</sub>	D	L <sub>MF</sub>	L <sub>E</sub>		L <sub>E1</sub>	L <sub>T</sub>	L <sub>1</sub>	R <sub>T</sub>	S <sub>1</sub>	V <sub>D</sub>	V <sub>FD</sub>	
					without brake	with brake								
32	MSM020B	16	42.0	45	109.0	140.5	7.0	25	12	M6	M3	5	30	
	MSM030B	16	60.0	55	111.0	144.0	7.0	25	18	M6	M4	5	30	
	MSK030C	16	54.0	55	188.0	213.0	7.0	25	18	M6	M4	5	30	
	VRDM368	16	57.2	45	116.0	157.0	5.0	25	18	M6	M4	5	30	
40	MSM020B	16	42.0	45	109.0	145.5	7.0	25	12	M6	M3	5	30	
	MSM030B	16	60.0	61	111.0	144.0	7.0	25	18	M6	M4	5	30	
	MSK030C	16	54.0	61	188.0	213.0	7.0	25	18	M6	M4	5	30	
	VRDM368	16	57.2	45	116.0	157.0	5.0	25	18	M6	M4	5	30	
50	MSM030C	16	60.0	73	138.5	171.5	7.0	25	18	M8	M4	5	33	
	MSK030C	16	54.0	73	188.0	213.0	7.0	25	18	M8	M4	5	33	
	MSK040C	16	82.0	73	185.5	215.0	8.0	25	22	M8	M6	5	33	
	VRDM397	16	85.0	73	110.0	157.0	10.0	25	25	M8	M6	5	33	
63	MSM040B	16	80.0	73	157.5	191.5	8.0	25	22	M8	M5	5	33	
	MSK040C	16	82.0	73	185.5	215.0	8.0	25	22	M8	M6	5	33	
	MSK050C	16	98.0	73	203.0	257.0	9.0	25	25	M8	M8	5	33	
	VRDM3910	16	85.0	73	140.0	186.5	10.0	25	25	M8	M6	5	33	
80	MSK040C	16	82.0	73	185.5	215.0	8.0	25	22	M10	M6	5	35	
	MSK050C	16	98.0	95	203.0	257.0	9.0	25	25	M10	M8	5	35	
	MSK060C	16	116.0	95	226.0	282.0	9.5	25	25	M10	M8	5	35	
	MSK076C	16	140.0	95	-	292.5	-	25	25	M10	M10	5	35	
100	VRDM3910	16	85.0	73	140.0	186.5	10.0	25	25	M10	M6	5	35	
	MSK060C	16	116.0	108	226.0	282.0	9.5	25	25	M10	M8	5	35	
	MSK076C	16	140.0	108	-	292.5	-	25	25	M10	M10	5	35	

## Dimensions EMC with belt side drive

This configuration of the EMC results in the shortest possible installation length  
The reduction gear ratio is 1:1.

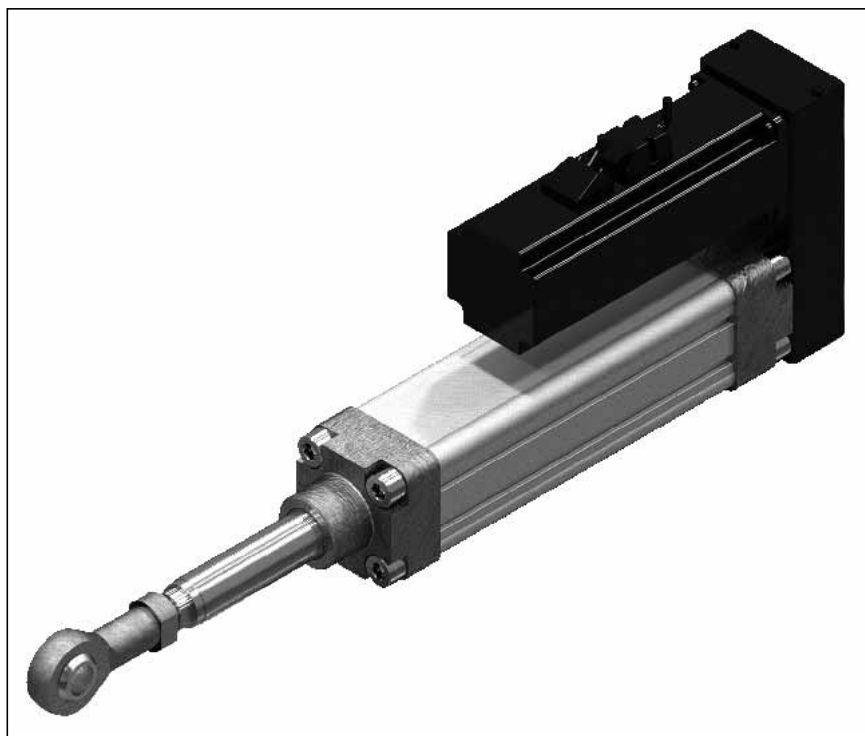



## Motors

### Type



The **MSK** range of IndraDyn S servo motors has a wide power spectrum and narrow size increments. The high torque density of these synchronous servo motors allows a particularly compact design with high torques.

#### Specification:

- Smooth shaft with shaft seal ring
- Multi-turn absolute encoder (Hiperface), 128 increments with 4096 revolutions. With this encoder type, the absolute axis position is saved even after the power is switched off.
- Cooling system: Natural convection
- Protection class IP65
- With or without holding brake

#### Product Advantages:

- High operational reliability
- Compact construction
- High-performance and dynamic
- High torque density
- High protection rating IP65
- Maximum precision through optical encoder



The maintenance-free EcoDrive Cs **servo motors MSM** expand the digital drive technology portfolio in the lower power range. Offering high power density in a compact design with minimized flange dimensions, this range of motors is ideal for machine concepts for high dynamic processes

#### Specification:

- Smooth shaft
- Multi-turn absolute encoder (Hiperface)
- Cooling system: Natural convection
- Protection class IP65
- With or without holding brake

#### Product Advantages:

- High operational reliability
- Maintenance-free operation (through brushless design and the use of long-lasting grease-lubricated bearings)
- High performance data
- High dynamics (through favorable torque-inertia mass ratio)
- Simple cable management and quick start-up



**VRDM stepper motors** are designed to be sturdy and have maintenance-free operation. Thanks to their optimized internal geometry, these motors offer high power density, with up to 50% more torque than conventional stepper motors of comparable size.

#### Specification:

- With encoder
- With or without holding brake

#### Product advantages:

- High power density
- Integrated thermal coil-control per EN-requirements for "Safe detachment"
- Very quiet and almost resonance-free operation

	Motor	Recommended controller	Electromechanical Cylinder EMC					
			32	40	50	63	80	100
	MSK 030 C	HCS02.1E-W0012						
	MSK 040 C	HCS02.1E-W0028						
	MSK 050 C	HCS02.1E-W0028						
	MSK 060 C	HCS02.1E-W0028						
	MSK 076 C	HCS02.1E-W0054						
	MSM 020B	DKC**.3-004						
	MSM 030B	DKC**.3-008						
	MSM 030C	DKC**.3-012						
	MSM 040B	DKC**.3-018						
	VRDM 368	TLD 011F						
	VRDM 397	TLD 011F						
	VRDM 3910	TLD 011F						
	VRDM 3913	TLD 011F						

# Motors

## AC servo motors MSK

### Dimensions

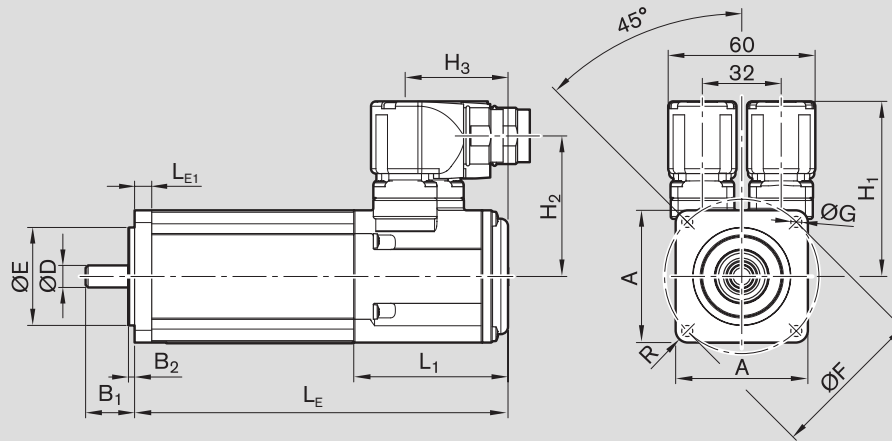

Motor type	Dimensions (mm)														
	A	B <sub>1</sub>	B <sub>2</sub>	ØD k6	ØE j6	ØF	ØG	H <sub>1</sub>	H <sub>2</sub>	H <sub>3</sub>	L <sub>E</sub> without brake	L <sub>E</sub> with brake	L <sub>E1</sub>	L <sub>1</sub>	R
MSK 030C	54	20	2.5	9	40	63	4.5	71.5	57.4	42.0	188.0	213.0	7.0	-	R5
MSK 040C	82	30	2.5	14	50	95	6.6	83.5	69.0	31.0	185.5	215.5	8.0	42.5	R8
MSK 050C	98	40	3.0	19	95	115	9.0	85.5	71.0	43.5	203.0	233.0	9.0	55.5	R8
MSK 060C	116	50	3.0	24	95	130	9.0	98.0	84.0	37.0	226.0	259.0	9.5	48.0	R9
MSK 076C	140	50	4.0	24	110	165	11.0	110.0	95.6	57.5	292.5	292.5	10.0	79.0	R12

### Motor data independent of EMC

Description	Symbol	Unit	MSK030C-0900	MSK040C-0600	MSK050C-0600	MSK060C-0600	MSK076C-0450
Part number	with brake		R347108503	R347108603	R347108903	R347109003	R347109303
	without brake		R347108403	R347108703	R347108803	R347109103	R347109203
Maximum useful speed	n <sub>max</sub>	(min <sup>-1</sup> )	9000	5600	5700	5200	5000
Maximum torque	M <sub>max</sub>	(Nm)	4	8.1	15	24	43.5
Rated torque	M <sub>N</sub>	(Nm)	0.8	2.7	5.0	8.0	12.0
Rotor mass moment of inertia	J <sub>rot</sub>	(10 <sup>-6</sup> kgm <sup>2</sup> )	30	140	330	800	4300
Mass without brake	m	(kg)	2.1	3.6	5.4	8.4	13.8
<b>Holding brake</b>							
Holding torque	M <sub>Br</sub>	(Nm)	1.0	4.0	5.0	10.0	11.0
Brake mass moment of inertia	J <sub>Br</sub>	(10 <sup>-6</sup> kgm <sup>2</sup> )	7	23	107	55	360
Mass of brake	m <sub>Br</sub>	(kg)	0.25	0.32	0.7	0.45	1.1

### Note

The motors can be delivered complete with controllers.  
 More information about motors and controllers can be found in the catalogs.

## Servo motors MSM

### Dimensions

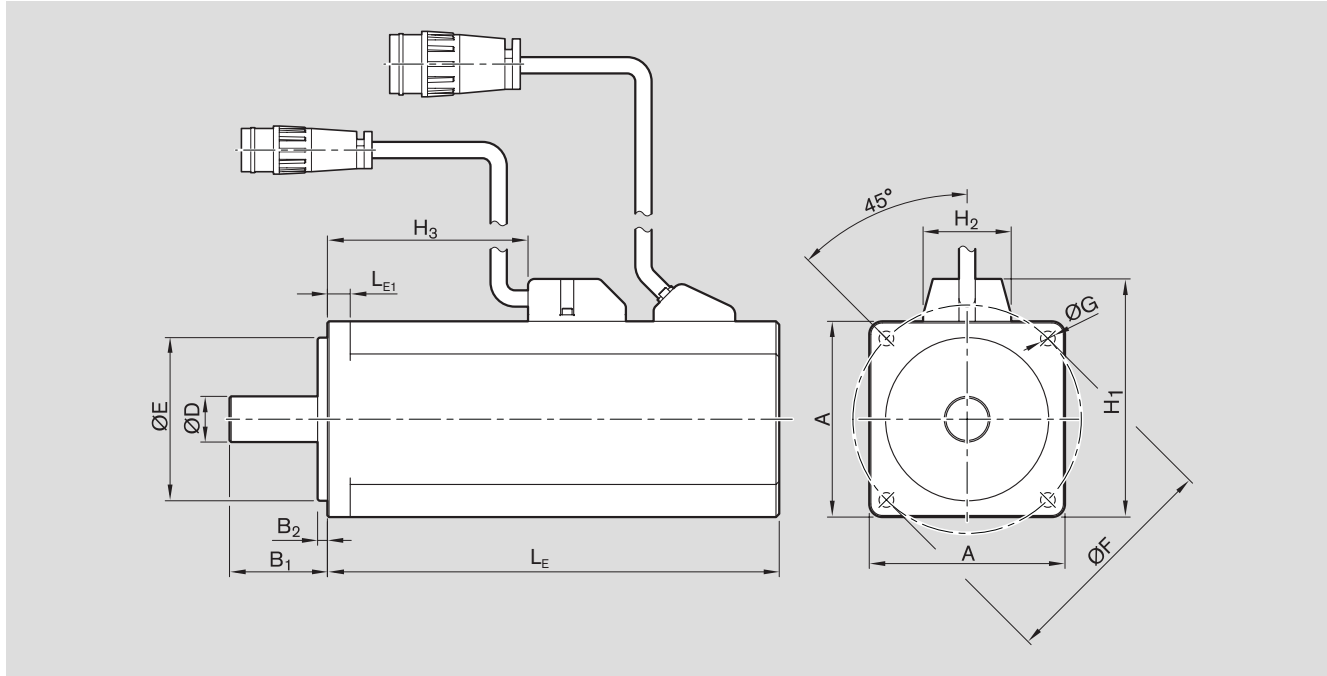

Motor type	Dimensions (mm)												
	A	B <sub>1</sub>	B <sub>2</sub>	ØD h6	ØE h7	ØF	ØG	H <sub>1</sub>	H <sub>2</sub>	H <sub>3</sub>	L <sub>E</sub> without brake	L <sub>E</sub> with brake	L <sub>E1</sub>
MSM 020B	42	24	2	8	22	48	34	55	27	38.8	109.0	140.5	7
MSM 030B	60	30	3	11	50	70	45	73	27	34.0	111.0	144.0	7
MSM 030C	60	30	3	14	50	70	4.5	73	27	61.5	138.5	171.5	7
MSM 040B	80	35	3	19	70	90	6.0	93	27	76.0	157.5	191.5	8

### Motor data independent of EMC

Description	Symbol	Unit	MSM 020B	MSM 030B	MSM 030C	MSM 040B
Part number	with brake		R347106903	R347107103	R347107303	R347107503
	without brake		R347106803	R347107003	R347107203	R347107403
Maximum useful speed	$n_{max}$	(min <sup>-1</sup> )	3000	3000	3000	3000
Maximum torque	$M_{max}$	(Nm)	0.95	1.91	3.8	7.1
Rated torque	$M_N$	(Nm)	0.30	0.64	1.2	2.4
Rotor mass moment of inertia	$J_{rot}$	(10 <sup>-6</sup> kgm <sup>2</sup> )	3.20	10.00	17.00	67.00
Mass without brake	$m$	(kg)	0.50	0.96	1.5	3.1
<b>Holding brake</b>						
Holding torque	$M_{Br}$	(Nm)	0.29	1.27	1.27	2.45
Brake mass moment of inertia	$J_{Br}$	(10 <sup>-6</sup> kgm <sup>2</sup> )	0.40	3.00	3.00	8.00
Mass of brake	$m_{Br}$	(kg)	0.20	0.40	0.4	0.7

### Note

The motors can be delivered complete with controllers.  
More information about motors and controllers can be found in the catalogs.

# Motors

## 3-phase stepper motors VRDM

### Dimensions

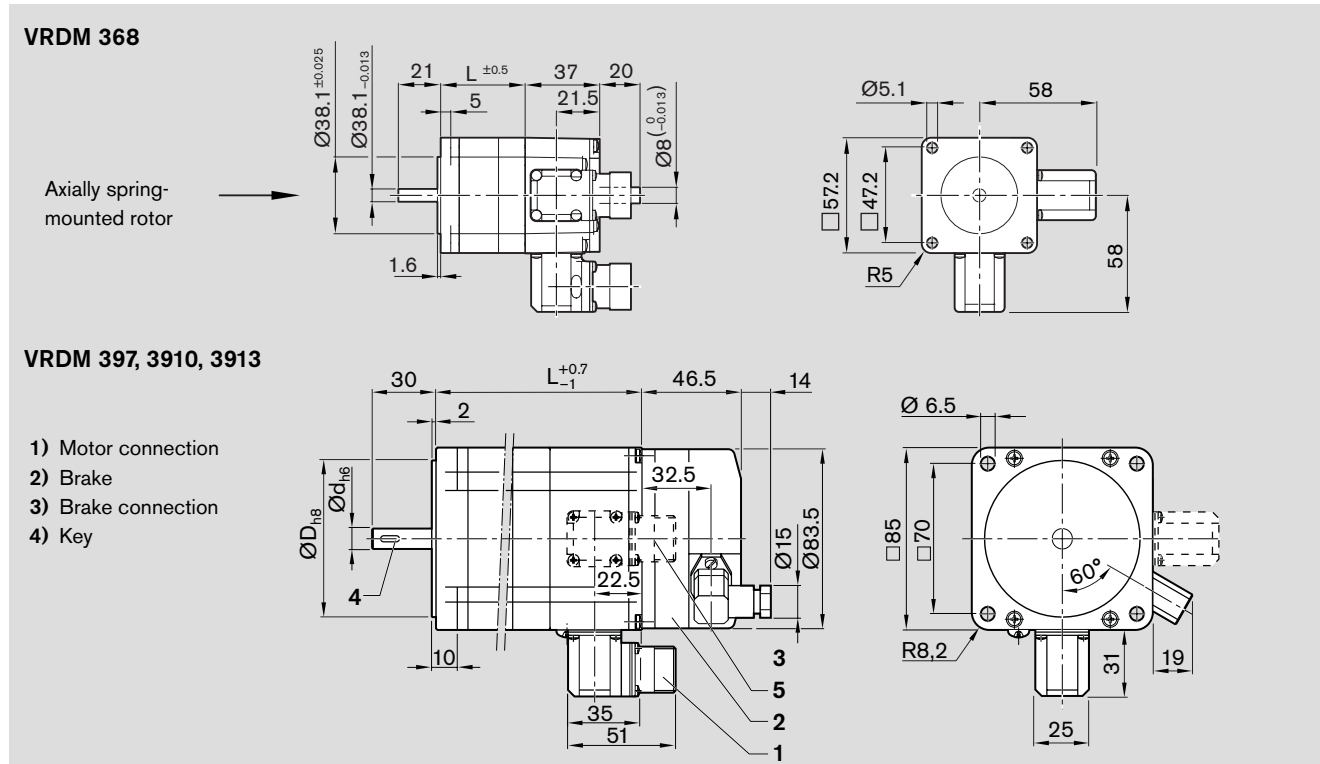

Motor type	Part number	Model holding brake		Shaft diameter d (mm)	Overall length L (mm)	Pilot diameter D (mm)
		without	with			
VRDM 368	R3471 035 06	X		8 -0.013	116	38.1 ±0.025
	R3471 036 06		X			
VRDM 397	R3471 037 06	X		12 h6	110	60.0 h8
	R3471 038 06		X			
VRDM 3910	R3471 039 06	X		12 h6	140	60.0 h8
	R3471 040 06		X			
VRDM 3913	R3471 041 06	X		14 h6	170	60.0 h8
	R3471 042 06		X			

### Motor data independent of EMC

Description	Symbol	Unit	VRDM 368	VRDM 397	VRDM 3910	VRDM 3913
Rated torque	$M_N$	(Nm)	1.5	2.0	4.0	6.0
Holding torque	$M_H$	(Nm)	1.7	2.26	4.52	6.78
Rotor mass moment of inertia w/o brake	$J_{rot}$	( $10^{-4}$ kgm <sup>2</sup> )	0.38	1.10	2.20	3.30
Step count	z		200/400/500/1000/2000/4000/5000/10000			
Step angle per step	a	(°)	1.8/0.9/0.72/0.36/0.18/0.09/0.072/0.036			
Encoder resolution			1000 increments/revolution			
Mass without brake	m	(kg)	1.00	2.05	3.10	4.20
<b>Holding brake</b>						
Holding torque	$M_{Br}$	(Nm)	1.0			6.0
Brake mass moment of inertia	$J_{Br}$	( $10^{-4}$ kgm <sup>2</sup> )	0.016			0.200
Mass of brake	$m_{Br}$	(kg)	0.5			1.5

### Note

The motors can be delivered complete with controllers.

# Notes

# Accessories

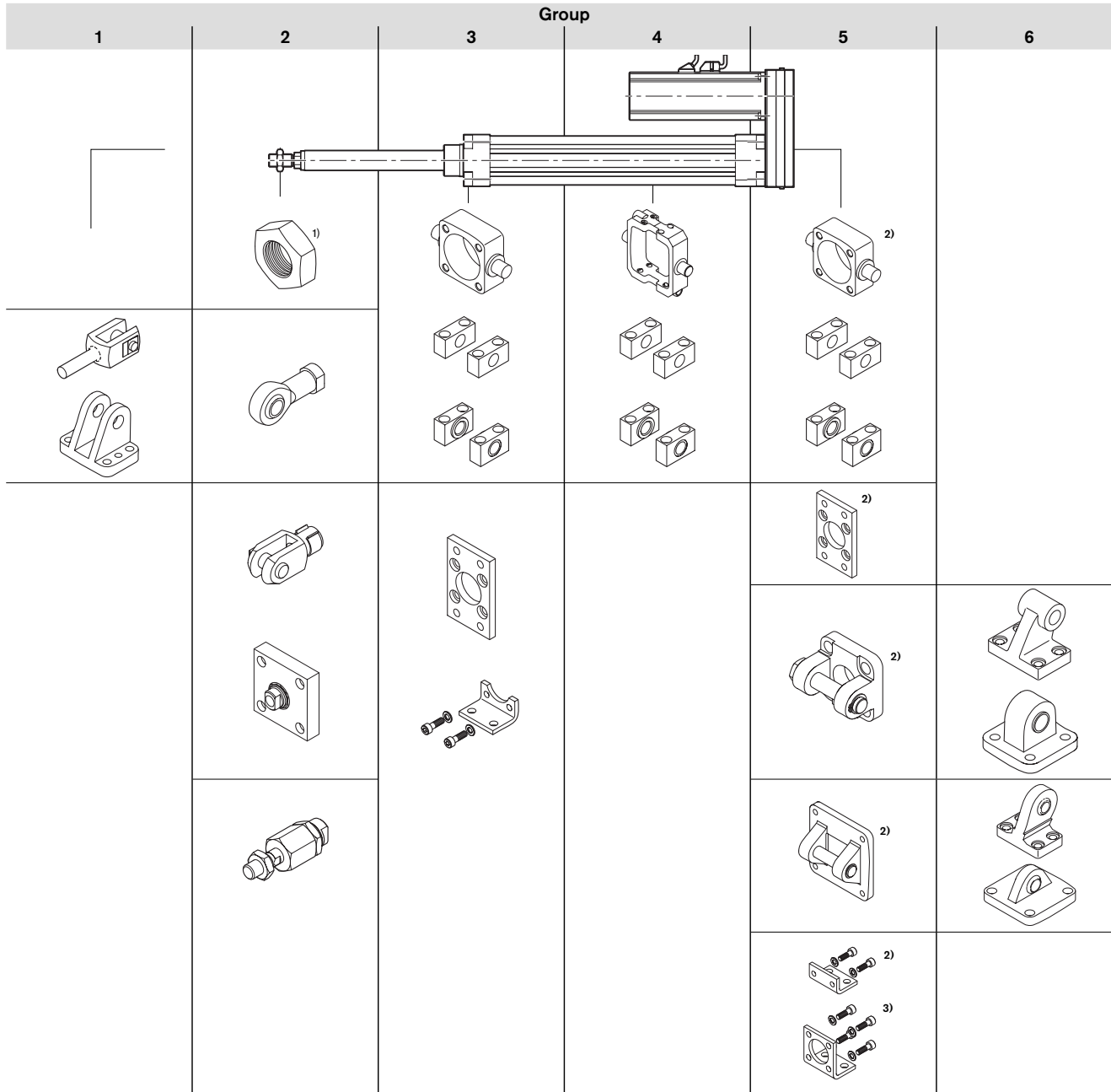

1) Nut is included in the scope of delivery. Can be ordered as an accessory

2) for RV0 3) only for MF0

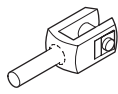
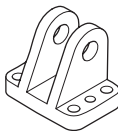
Group	Description	Size	Part number
1	 Clevis	32	R3499 361 00
		40	R3499 362 00
		50	R3499 363 00
		63	R3499 364 00
		80	R3499 365 00
		100	R3499 366 00
1	 Counter support block	32	R3499 373 00
		40	R3499 374 00
		50	R3499 375 00
		63	R3499 376 00
		80	R3499 377 00
		100	R3499 378 00

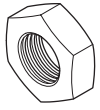
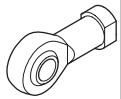
Group	Description	Size	Part number
2	 Nut	32	R1823 300 020
		40	R1823 300 021
		50	R1823 300 030
		63	R1823 300 030
		80	R1823 300 031
		100	R1823 300 031
2	 Spherical bearing	32	R3499 385 00
		40	R3499 386 00
		50	R3499 387 00
		63	R3499 388 00
		80	R3499 389 00
		100	R3499 390 00

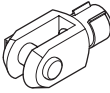
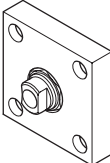
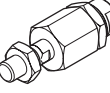
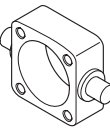
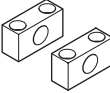
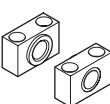
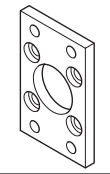
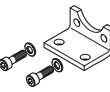
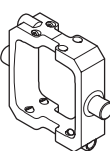
Group	Description	Size	Part number
2	Clevis 	32	R3499 391 00
		40	R3499 392 00
		50	R3499 393 00
		63	R3499 394 00
		80	R3499 395 00
		100	R3499 396 00
2	Balance coupling with attachment plate 	32	R3499 397 00
		40	R3499 398 00
		50	R3499 399 00
		63	R3499 400 00
		80	R3499 401 00
		100	R3499 402 00
2	Flex-coupling 	32	R3499 379 00
		40	R3499 380 00
		50	R3499 381 00
		63	R3499 382 00
		80	R3499 383 00
		100	R3499 384 00
3, 5	Trunnion 	32	R3499 403 00
		40	R3499 404 00
		50	R3499 405 00
		63	R3499 406 00
		80	R3499 407 00
		100	R3499 408 00
3, 4, 5	Bearing for trunnion 	32	R3499 409 00
		40	R3499 410 00
		50	R3499 411 00
		63	R3499 412 00
		80	R3499 413 00
		100	R3499 414 00
3, 4, 5	Bearing for trunnion - plastic 	32	R3499 415 00
		40	R3499 416 00
		50	R3499 417 00
		63	R3499 418 00
		80	R3499 419 00
		100	R3499 420 00
3, 5	Head/end cap attachment 	32	R3499 421 00
		40	R3499 422 00
		50	R3499 423 00
		63	R3499 424 00
		80	R3499 425 00
		100	R3499 426 00
3	Flange mount attachment A 	32	R3499 427 00
		40	R3499 428 00
		50	R3499 429 00
		63	R3499 430 00
		80	R3499 431 00
		100	R3499 432 00
4	Pivot attachment 	32	R3499 433 00
		40	R3499 434 00
		50	R3499 435 00
		63	R3499 436 00
		80	R3499 437 00
		100	R3499 438 00

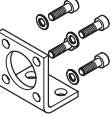
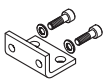
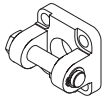
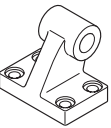
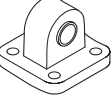
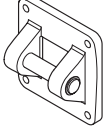
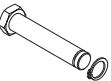
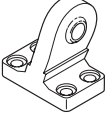
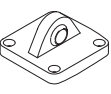
Group	Description	Size	Part number
5	Flange mount attachment 	32	R3499 439 00
		40	R3499 440 00
		50	R3499 441 00
		63	R3499 442 00
		80	R3499 443 00
		100	R3499 444 00
5	Flange mount attachment B 	32	R3499 445 00
		40	R3499 446 00
		50	R3499 447 00
		63	R3499 448 00
		80	R3499 449 00
		100	R3499 450 00
5	Counter support bearing D 	32	R3499 457 00
		40	R3499 458 00
		50	R3499 459 00
		63	R3499 460 00
		80	R3499 461 00
		100	R3499 462 00
6	Bearing block CETOP 	32	R3499 475 00
		40	R3499 476 00
		50	R3499 477 00
		63	R3499 478 00
		80	R3499 479 00
		100	R3499 480 00
6	Swivel mount 	32	R3499 481 00
		40	R3499 482 00
		50	R3499 483 00
		63	R3499 484 00
		80	R3499 485 00
		100	R3499 486 00
5	Fork head swivel joint attachment for spherical bearing 	32	R3499 451 00
		40	R3499 452 00
		50	R3499 453 00
		63	R3499 454 00
		80	R3499 455 00
		100	R3499 456 00
5	Bolt 	32	R3499 367 00
		40	R3499 368 00
		50	R3499 369 00
		63	R3499 370 00
		80	R3499 371 00
		100	R3499 372 00
6	Counter support C 	32	R3499 463 00
		40	R3499 464 00
		50	R3499 465 00
		63	R3499 466 00
		80	R3499 467 00
		100	R3499 468 00
6	Counter support B 	32	R3499 469 00
		40	R3499 470 00
		50	R3499 471 00
		63	R3499 472 00
		80	R3499 473 00
		100	R3499 474 00

# Permissible Speeds

## EMC 32

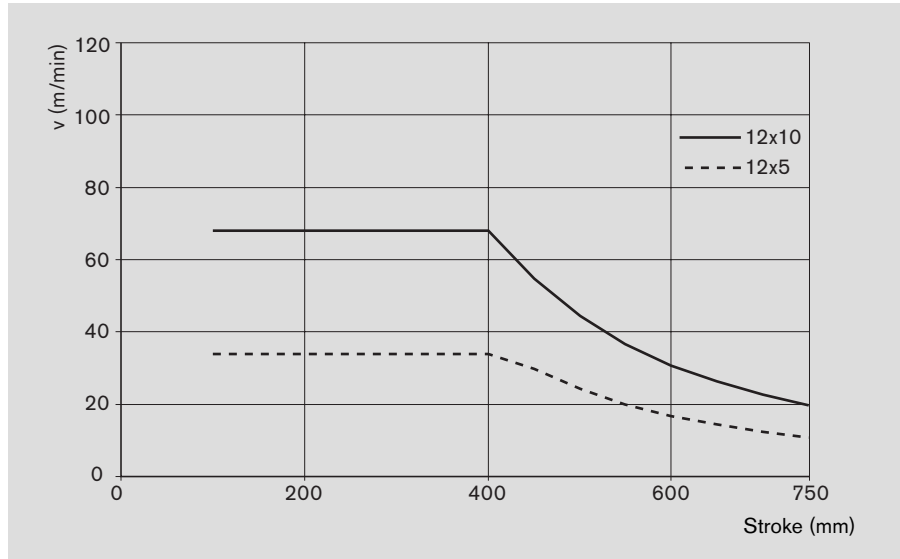

## EMC 40

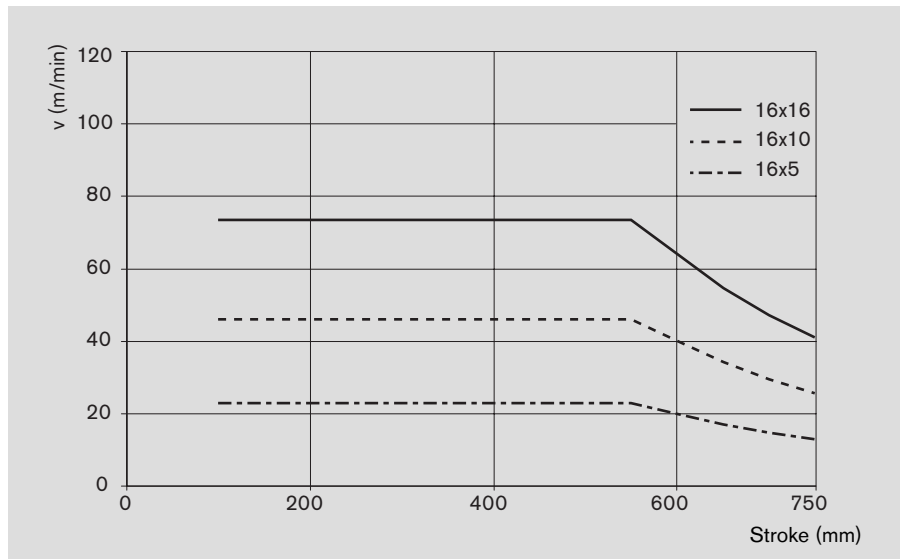

## EMC 50

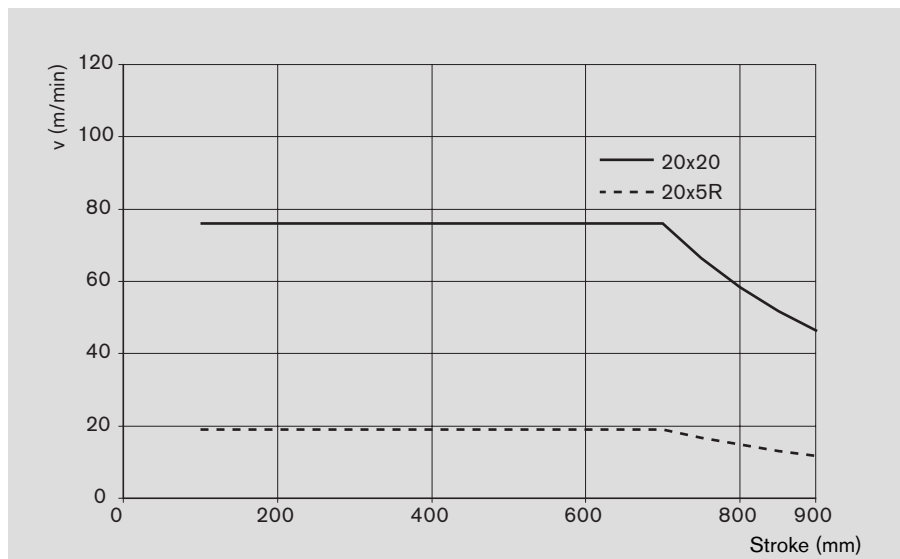

**EMC 63**

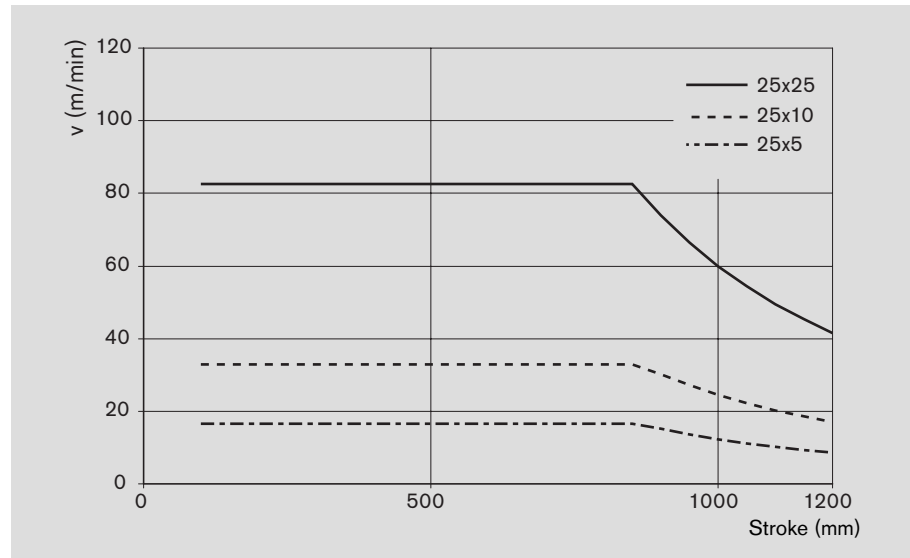

**EMC 80**

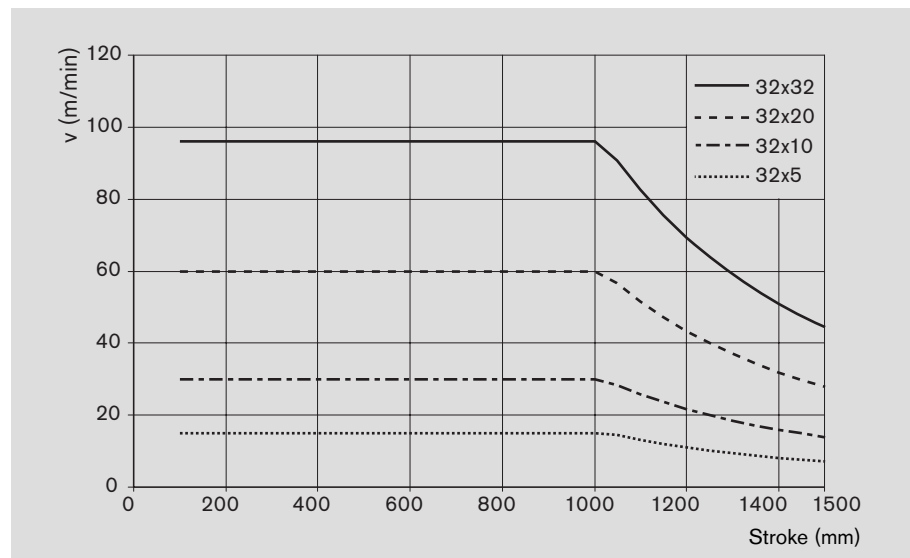

**EMC 100**

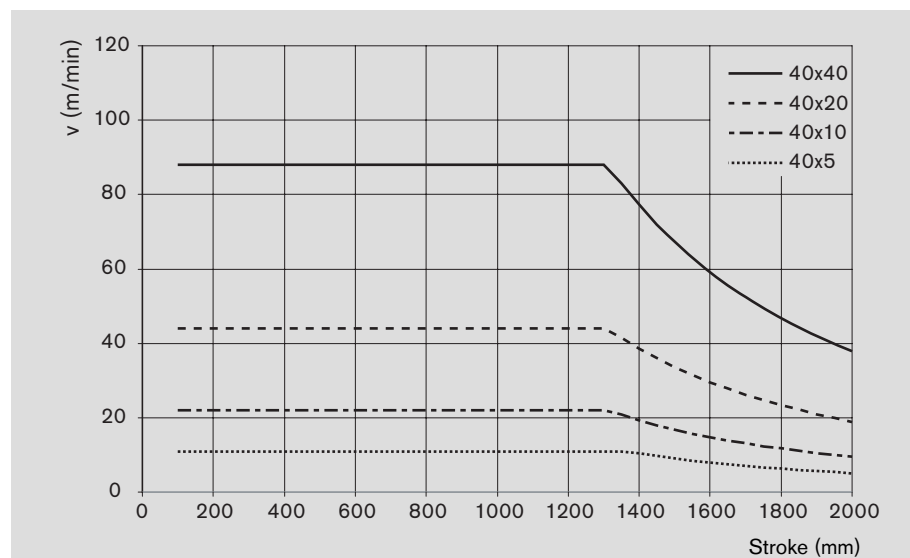

# Permissible Drive Torque

## EMC 32

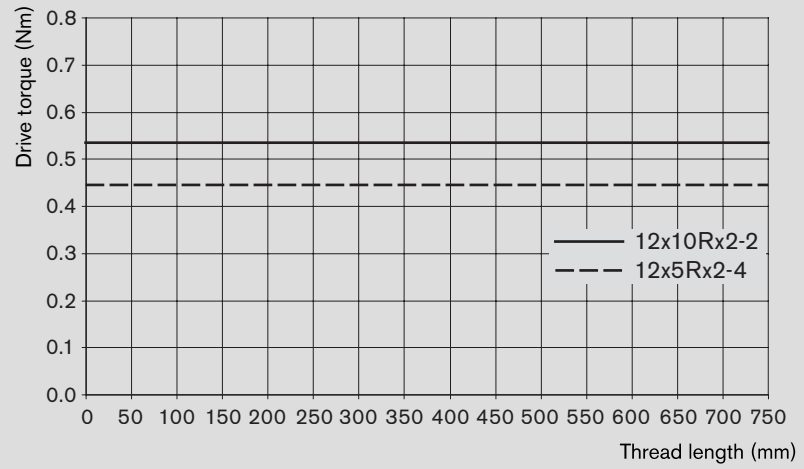
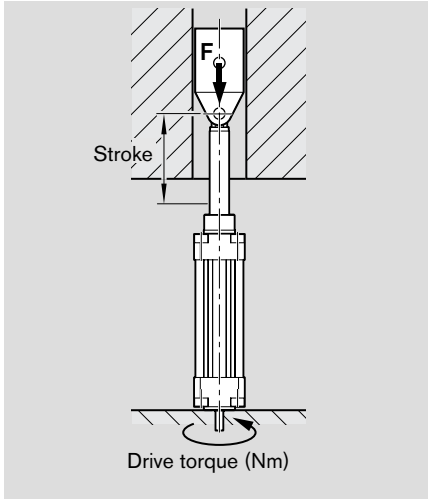

## EMC 40

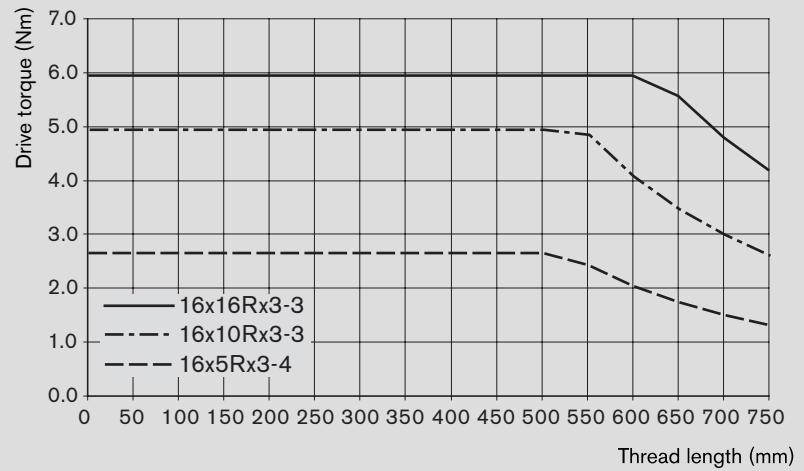

## EMC 50

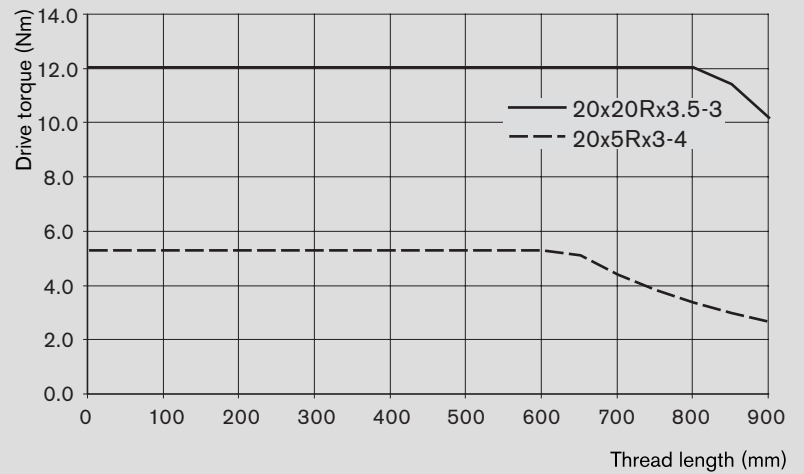

**EMC 63**

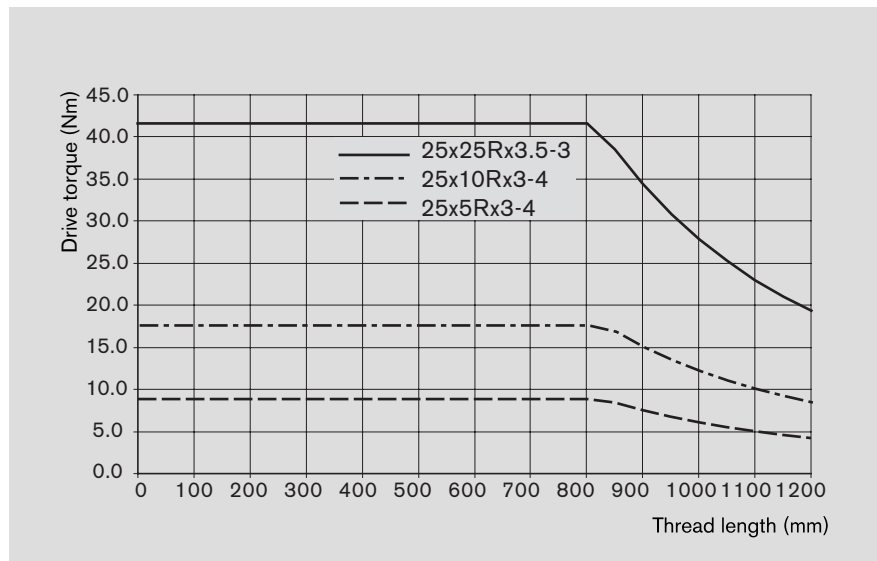

**EMC 80**

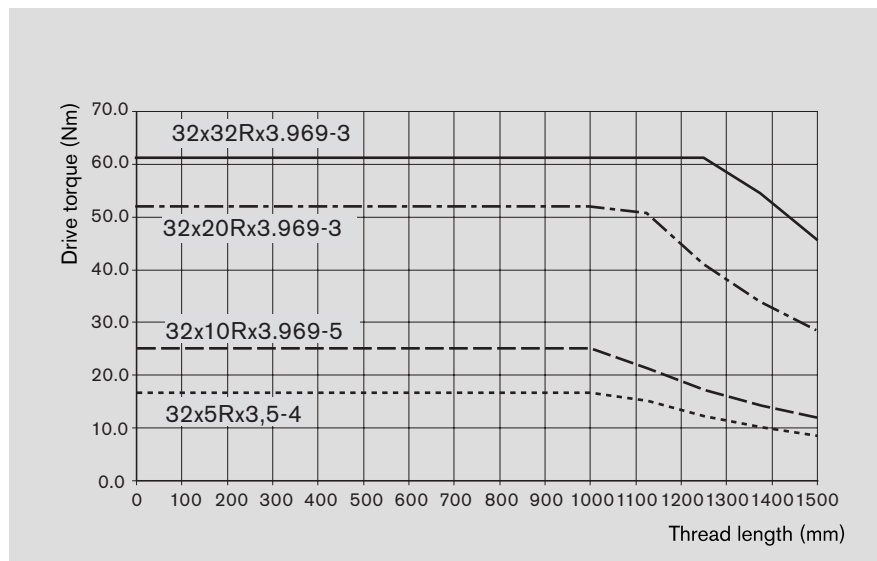

**EMC 100**

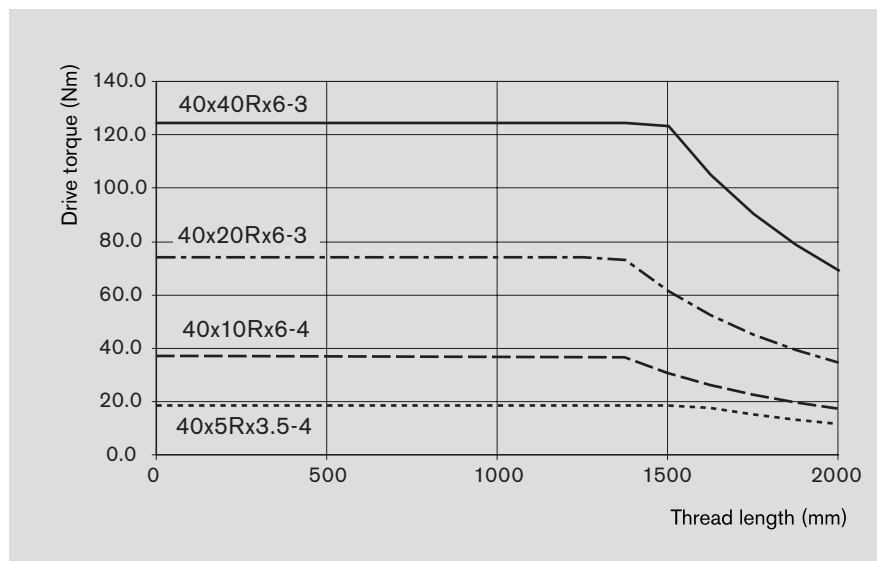

# Permissible Axial Force

**EMC 32**

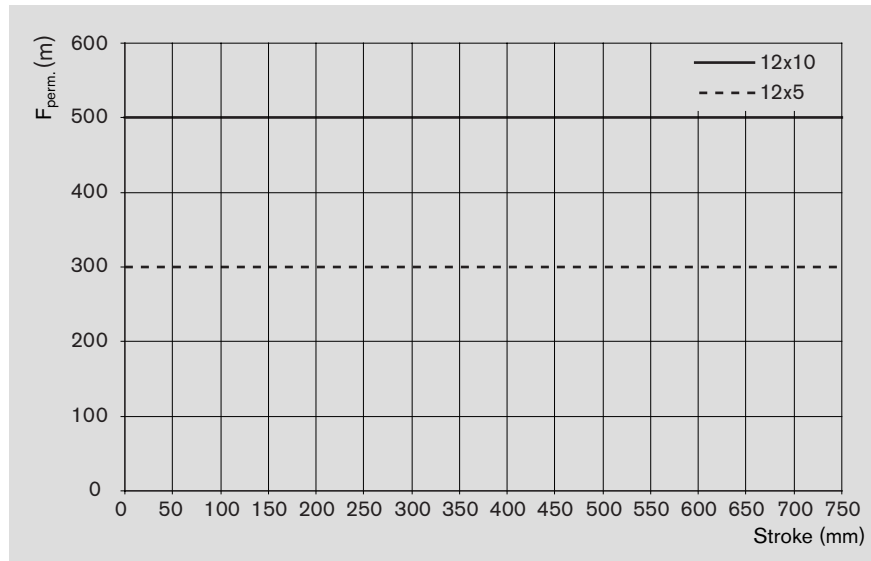
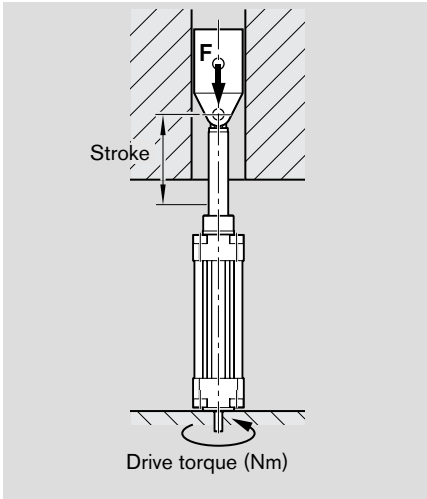

**EMC 40**

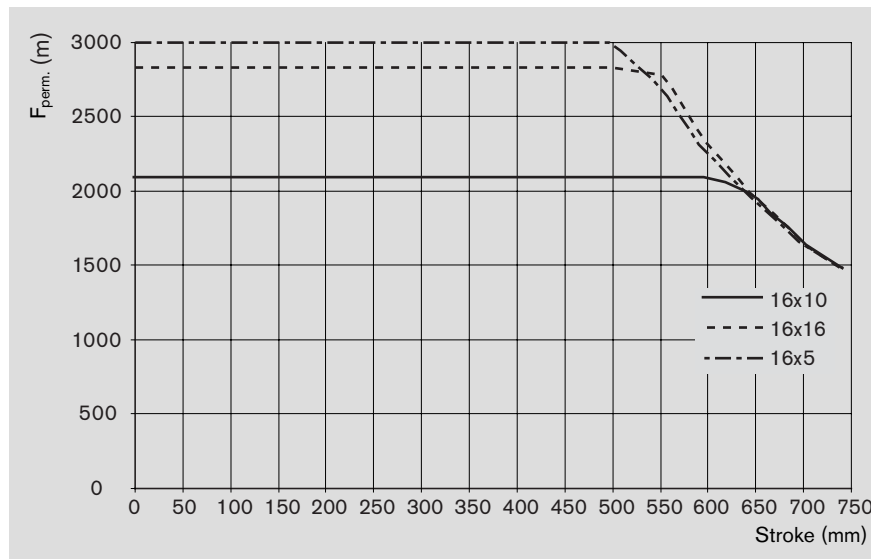

**EMC 50**

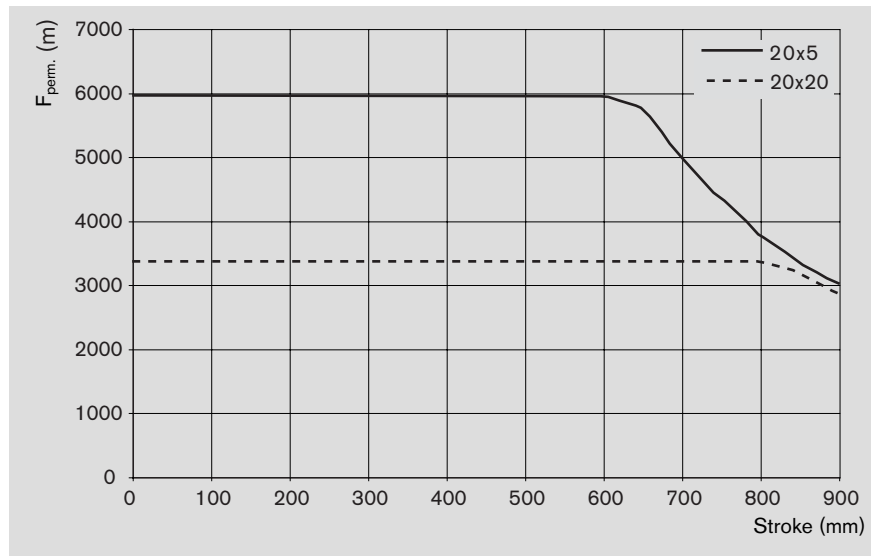

**EMC 63**

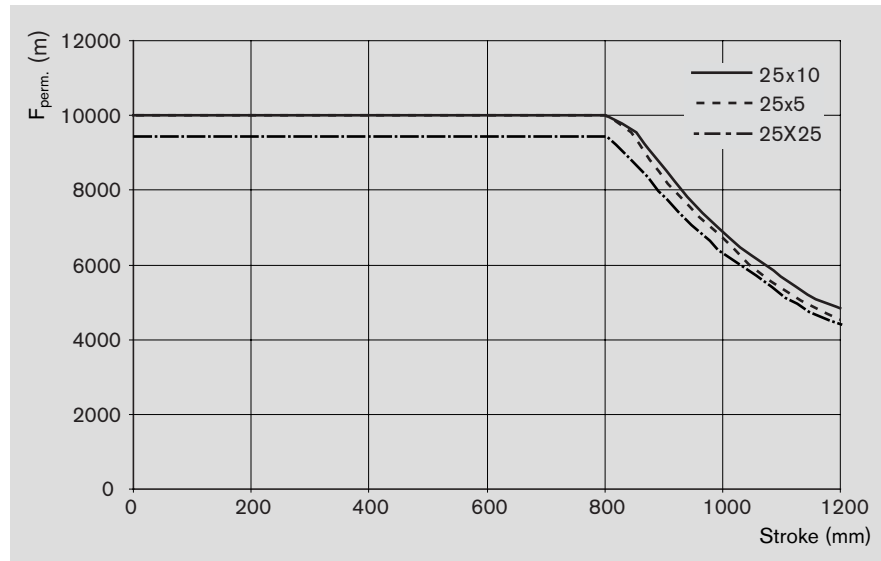

**EMC 80**

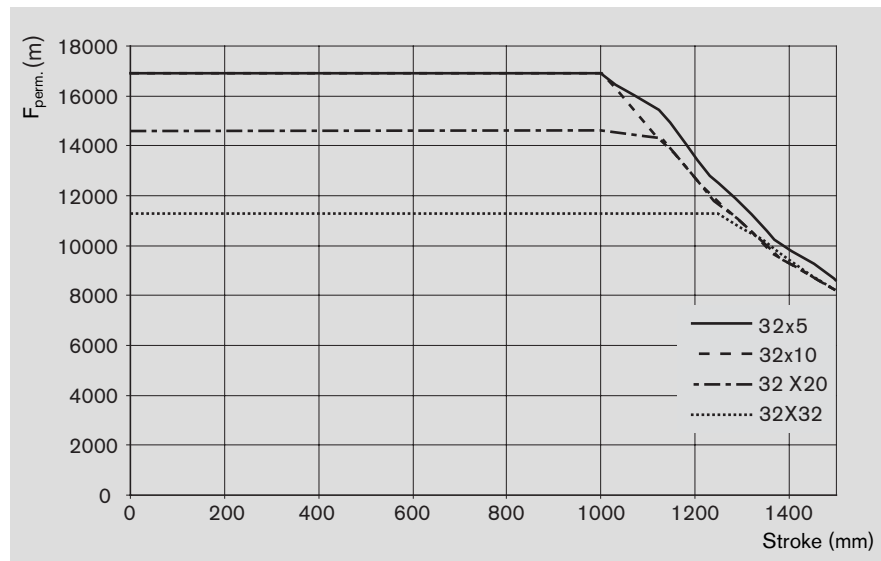

**EMC 100**

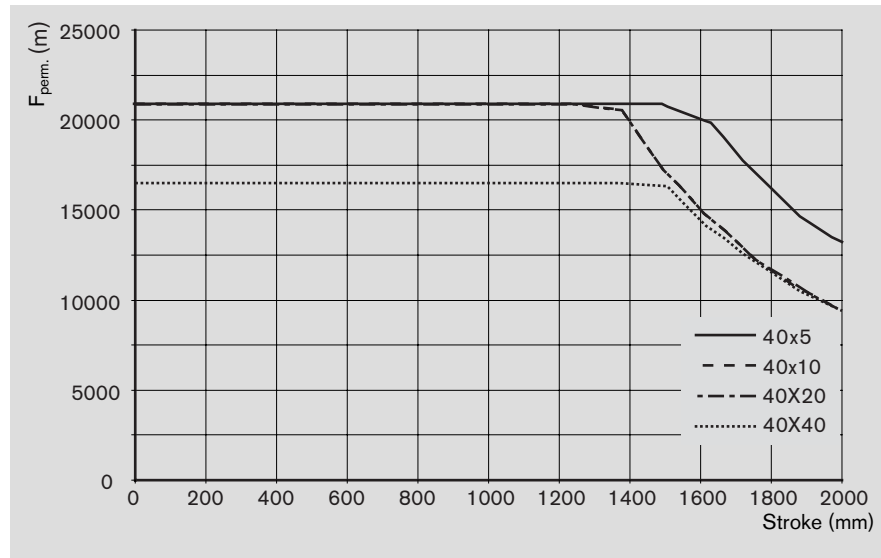

## Configuration and Ordering

Size	Ball screw drive								
	Lead (mm)	Stroke (mm)	Seal system	Preload	Accuracy class	Ball nut	Screw shaft end		
EMC32	[5]	[...]	Standard [01]	Reduced backlash [01]	[T7]	Standard [00]	Standard [00]		
	[10]								
EMC40	[5]	[...]	Standard [01]	Reduced backlash [01]	[T7]	Standard [00]	Standard [00]		
	[10]								
	[16]								
EMC50	[5]	[...]	Standard [01]	Reduced backlash [01]	[T7]	Standard [00]	Standard [00]		
	[20]								

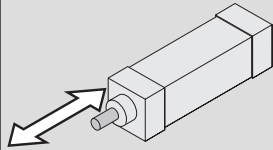



**Order example:**

Ordering data		
Option	Option code	Description
EMC	EMC50	Electromechanical Cylinder size 50
Lead	[5]	Lead 5 mm
Stroke	[200]	Nominal stroke 200 mm
KGT-nut	[00]	Standard
Journal	[00]	Standard
Motor mount	[RV02]	Belt drive, option 2
Adaptor kit for motor	[23]	Attachment kit for belt drive for Motor MSM 030C
Motor	[73]	Motor MSM 030C with brake
Documentation	[000]	Standard documentation
Accessories 1	Group 1	Clevis
Accessories 2	Group 2	Spherical bearing
Accessories 3	Group 5	Head/end cap attachment

**When ordering:**

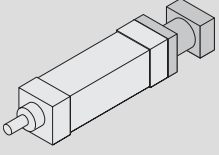
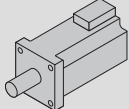
Please state the option number given in the box, as appropriate (e.g. [01])

Motor mount		Motor		Documentation	
					
Fig. 1, Fig. 2	Gear reduction	Attachment kit for motor	without brake	with brake	
OF01		00	00		
MF01		00	01 MSM020B	68	69
			02 MSM030B	70	71
			05 MSK030C	84	85
			10 VRDM368	35	36
RV01 RV02 RV03 RV04	Standard i=1	00	21 MSM020B	68	69
			22 MSM030B	70	71
			25 MSK030C	84	85
			30 VRDM368	35	36
OF01		00	00		
MF01		00	01 MSM020B	68	69
			02 MSM030B	70	71
			05 MSK030C	84	85
			10 VRDM368	35	36
RV01 RV02 RV03 RV04	Standard i=1	00	21 MSM020B	68	69
			22 MSM030B	70	71
			25 MSK030C	84	85
			30 VRDM368	35	36
OF01		00	00		
MF01		00	03 MSM030C	72	73
			05 MSK030C	84	85
			06 MSK040C	86	87
			11 VRDM397	37	38
RV01 RV02 RV03 RV04	Standard i=1	00	23 MSM030C	72	73
			25 MSK030C	84	85
			26 MSK040C	86	87
			31 VRDM397	37	38

Standard 000  
(acceptance test report)

Motor mount / Attachment kit

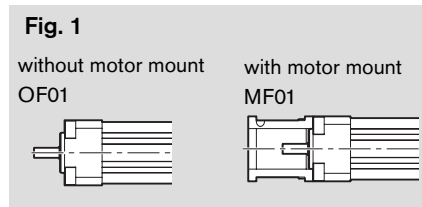

Belt driven

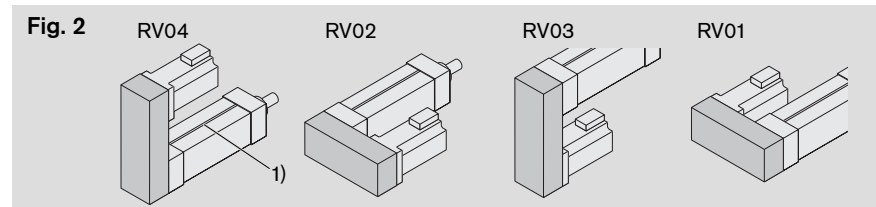

1) Slot for switches

## Configuration and Ordering



Size	Ball screw drive									
	Lead (mm)	Stroke (mm)	Seal system	Preload		Accuracy class	Ball nut		Screw shaft end	
EMC63	5	...	Standard 01	Reduced backlash 01		T7	Standard 00		Standard 00	
	10									
	25									
EMC80	5	...	Standard 01	Reduced backlash 01		T7	Standard 00		Standard 00	
	10									
	20									
	32									
EMC100	5	...	Standard 01	Reduced backlash 01		T7	Standard 00		Standard 00	
	10									
	20									
	40									

**Order example:**

Ordering data		
Option	Option code	Description
EMC	EMC80	Electromechanical Cylinder EMC size 80
Lead	5	Lead 5 mm
Stroke	200	Nominal stroke 200 mm
Ball nut	00	Standard
Screw shaft end	00	Standard
Motor attachment	RV02	Belt drive, option 2
Attachment kit for	27	Attachment kit for belt drive for Motor MSK050C
Motor	89	Motor MSK050C with brake
Documentation	000	Standard documentation
Accessories 1	Group 1	Clevis
Accessories 2	Group 2	Spherical bearing
Accessories 3	Group 5	Head/end cap attachment

**When ordering:**

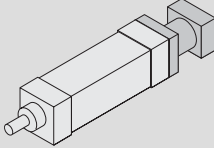
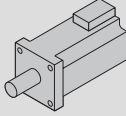
Please state the option number given in the box, as appropriate (e.g. 01)

Motor mount		Motor		Documentation
				
Fig. 1, Fig. 2	Gear reduction	Attachment kit for motor	without brake	with brake
OF01	00	00	00	
MF01	00	04 MSM040B	74	75
		06 MSK040C	86	87
		07 MSK050C	88	89
		11 VRDM3910	39	40
RV01 RV02 RV03 RV04	Standard i=1	24 MSM040B	74	75
		26 MSK040C	86	87
		27 MSK050C	88	89
		31 VRDM3910	39	40
OF01	00	00	00	
MF01	00	04 MSM040B	74	75
		07 MSK050C	88	89
		08 MSK060C	90	91
		09 MSK076C	92	93
		12 VRDM3913	39	40
RV01 RV02 RV03 RV04	Standard i=1	24 MSM040B	74	75
		27 MSK050C	88	89
		28 MSK060C	90	91
		29 MSK076C	92	93
		32 VRDM3913	39	40
OF01	00	00	00	
MF01	00	08 MSK060C	90	91
		09 MSK076C	92	93
		13 VRDM31117	43	44
		28 MSK060C	90	91
RV01 RV02 RV03 RV04	Standard i=1	29 MSK076C	92	93
		33 VRDM31117	43	44

Standard (acceptance test report) 000

Motor mount / Attachment kit

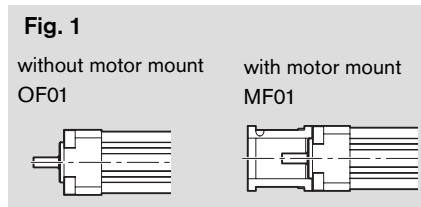

Belt driven

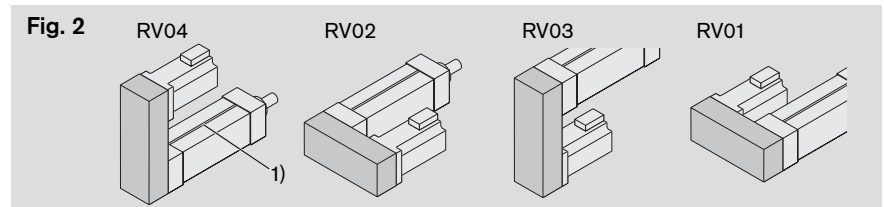

1) Slot for switches

# Inquiry / Order Form

Bosch Rexroth Corporation  
 14001 South Lakes Drive  
 Charlotte, NC 28273

Phone: (704) 583-4338 / 800-438-5983  
 Fax: (704) 583-0523

www.boschrexroth-us.com

**For an explanation of ordering parameters, see pages 26-28 "Configuration and Ordering"**

Ordering example: EMC80		
Ordering data		Explanation
Size	= EMC80	
Lead	= 5	Lead 5 mm
Stroke	= 200	Nominal stroke 200 mm
Ball nut	= 00	Standard
Screw shaft end	= 00	Standard
Motor attachment	= RV02	Belt drive option 2
Attachment kit	= 27	Attachment kit: belt drive for motor MSK050C
Motor	= 89	Motor MSK050C with brake
Documentation	= 000	Standard documentation
Accessories 1	= group 1	Clevis
Accessories 2	= group 2	Spherical bearing
Accessories 3	= group 5	Head/end cap attachment

To be completed by customer: Inquiry  / Order

**Electromechanical Cylinder EMC**

Size = \_\_\_\_\_

Lead = \_\_\_\_\_

Stroke = \_\_\_\_\_

Ball nut = 00

Screw shaft end = 00

Motor attachment = \_\_\_\_\_

Attachment kit = \_\_\_\_\_

Motor = \_\_\_\_\_

Documentation = \_\_\_\_\_

Accessories 1 = \_\_\_\_\_

Accessories 2 = \_\_\_\_\_

Accessories 3 = \_\_\_\_\_

**Quantities:** \_\_\_\_\_ pcs, \_\_\_\_\_ per month, \_\_\_\_\_ per year, per order, or \_\_\_\_\_

Comments:

---

**From**

Company: \_\_\_\_\_ Name: \_\_\_\_\_

Address: \_\_\_\_\_ Department: \_\_\_\_\_

\_\_\_\_\_ Telephone: \_\_\_\_\_

\_\_\_\_\_ Fax: \_\_\_\_\_



Bosch Rexroth Corporation  
Linear Motion and  
Assembly Technologies  
14001 South Lakes Drive  
Charlotte, NC 28273  
Telephone (800) 438-5983  
Facsimile (704) 583-0523  
[www.boschrexroth-us.com](http://www.boschrexroth-us.com)

Bosch Rexroth Corporation  
Corporate Headquarters  
5150 Prairie Stone Parkway  
Hoffman Estates, IL 60192-3707  
Telephone (847) 645-3600  
Facsimile (847) 645-6201

Bosch Rexroth Corporation  
Industrial Hydraulics  
2315 City Line Road  
Bethlehem, PA 18017-2131  
Telephone (610) 694-8300  
Facsimile (610) 694-8467

Bosch Rexroth Corporation  
Electric Drives and Controls  
5150 Prairie Stone Parkway  
Hoffman Estates, IL 60192-3707  
Telephone (847) 645-3600  
Facsimile (847) 645-6201

Bosch Rexroth Corporation  
Pneumatics  
1953 Mercer Road  
Lexington, KY 40511-1021  
Telephone (859) 254-8031  
Facsimile (859) 281-3491

Bosch Rexroth Corporation  
Mobile Hydraulics  
1700 Old Mansfield Road  
Wooster, OH 44691-0394  
Telephone (330) 263-3300  
Facsimile (330) 263-3333